

## SECTION 6

# INDEX

<b>Dust Cover</b> .....	<b>6-4</b>
<b>Dust Shield Kits</b> .....	<b>6-5</b>
<b>Dust Shield Washers</b> .....	<b>6-4</b>
<b>Dust Shields</b> .....	<b>6-ii</b>
<b>Plugs</b> .....	<b>6-4</b>

# DUST SHIELDS

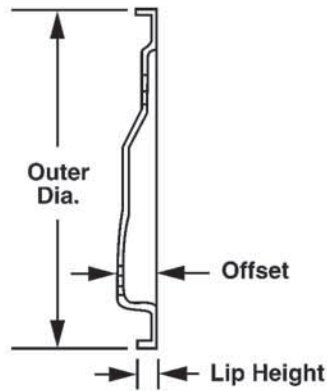
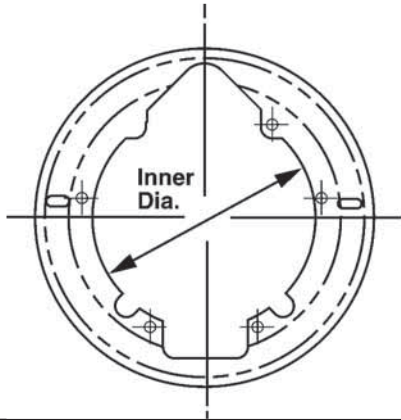

PART NUMBER	OUTER DIA.	INNER DIA.	OFFSET	LIP HEIGHT	NO. OF HOLES	SIZE OF HOLES	APPLICATION INFORMATION
A-3264-G-1281	15-63/64"	10-13/64"	1-11/32"	55/64"	4	5/16"	Use on 15" x 4" Q brakes.

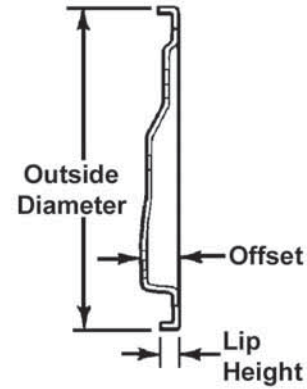
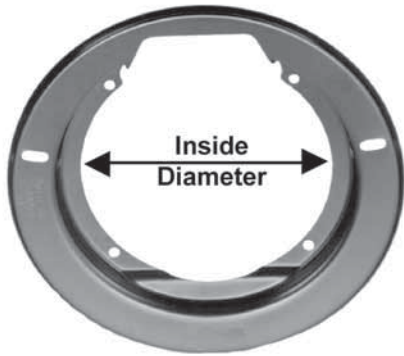

PART NUMBER	OUTER DIA.	INNER DIA.	OFFSET	LIP HEIGHT	NO. OF HOLES	SIZE OF HOLES	APPLICATION INFORMATION
3264-R-1292	16-9/16"	10-1/2"	1-5/32"	39/64"	4	7/16"	Use on 15" x 4" Q Plus™ brakes.

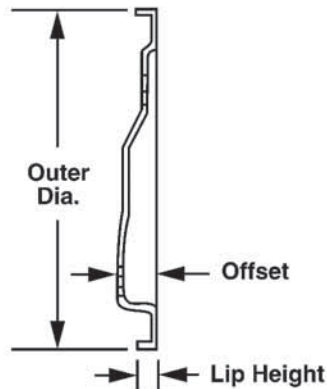
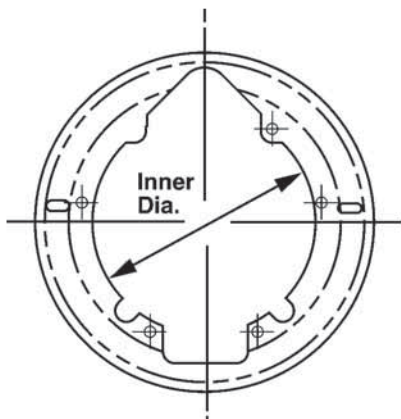

PART NUMBER	OUTER DIA.	INNER DIA.	OFFSET	LIP HEIGHT	NO. OF HOLES	SIZE OF HOLES	APPLICATION INFORMATION
3264-E-1279	16-7/8"	10-3/16"	1-15/32"	15/16"	4	5/16"	Use on 15" x 4" Q brakes.

# DUST SHIELDS

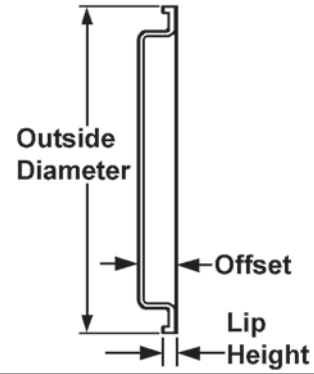
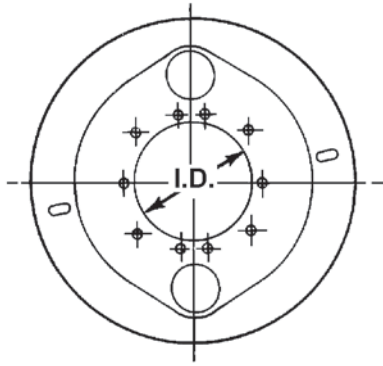

PART NUMBER	OUTER DIA.	INNER DIA.	OFFSET	LIP HEIGHT	NO. OF HOLES	SIZE OF HOLES	APPLICATION INFORMATION
A-3236-M-1521	17"	6-5/8"	1-15/16"	1/2"	10	23/32"	Use on 15" x 7" wedge brakes with forged spider.

6

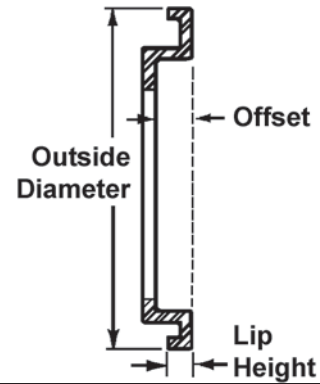
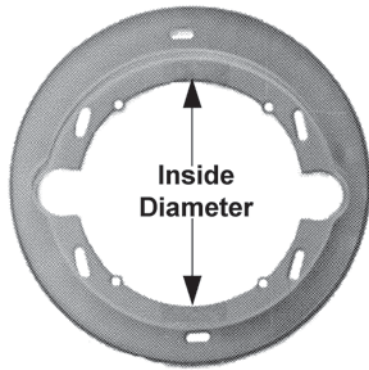

PART NUMBER	OUTER DIA.	INNER DIA.	OFFSET	LIP HEIGHT	NO. OF HOLES	SIZE OF HOLES	APPLICATION INFORMATION
3736-P-328	17"	10-31/64"	1-11/16"	1/2"	4	25/64"	Use on 15" RD brakes. With two extra holes 11/32" diameter.
3264-A-1067	17"	10-31/64"	1-11/16"	1/2"	4	25/64"	Use on 15" RD brakes.

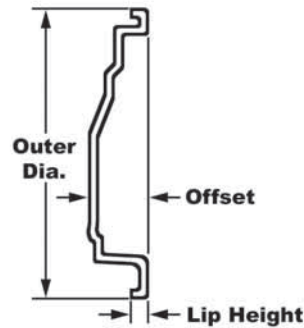
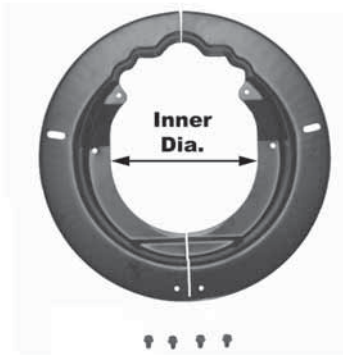

PART NUMBER	OUTER DIA.	INNER DIA.	OFFSET	LIP HEIGHT	NO. OF HOLES	SIZE OF HOLES	APPLICATION INFORMATION
A2-3264-P-1082	18-1/8"	9-5/8"	2-25/64"	9/16"	4	11/32"	16-1/2" x 7" Q Plus™
A-3264-C-1381	18-1/8"	9-5/8"	3-13/64"	7/8"	4	11/32"	16-1/2" x 8" Q Plus™

# DUST SHIELDS

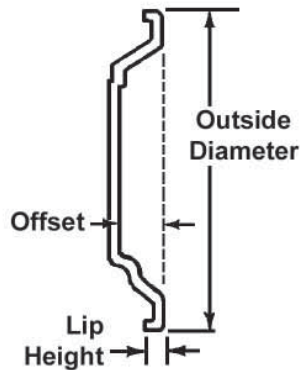
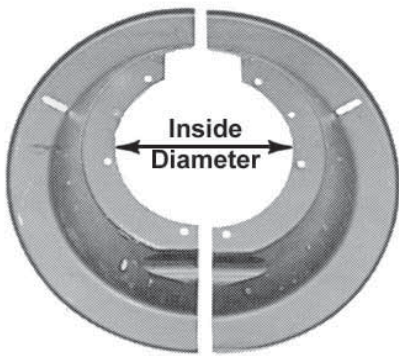

PART NUMBER	OUTER DIA.	INNER DIA.	OFFSET	LIP HEIGHT	NO. OF HOLES	SIZE OF HOLES	APPLICATION INFORMATION
A1-3236-A-1249	18-1/8"	7-13/16"	2-13/16"	1/2"	8	3/8"	Use on 16-1/2" P brakes with cast spider. Replaces: 211102001, 331476, 331478, B1688A, L3182, L556, L738, M1583, M16WB100, M16WB101, M590A, UB1165, UB1172, UB5102

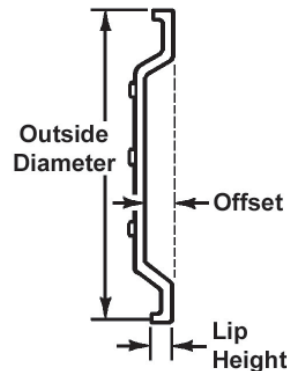
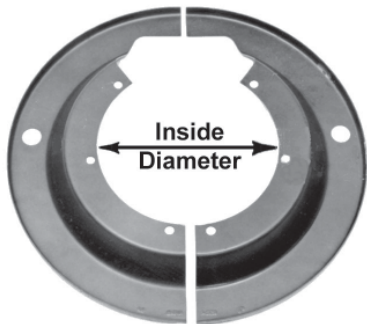

PART NUMBER	OUTER DIA.	INNER DIA.	OFFSET	LIP HEIGHT	NO. OF HOLES	SIZE OF HOLES	APPLICATION INFORMATION
A-3736-W-907	18-1/8"	8-15/16"	1-5/8"	9/16"	6	7/16"	Use on 16-1/2" x 7" P brakes. Replaces 331489
A1-3736-M-91	18-1/8"	9-5/8"	3/4"	21/32"	6	7/16"	Use on 16-1/2" x 7" P brakes
A1-3264-J-114	18-1/8"	9-7/8"	3/4"	2-1/32"	6	7/16"	Use on 16-1/2" x 6" P brakes.
A2-3236-Q-2123	18-1/8"	10-1/8"	1-1/2"	2-1/32"	6	7/16"	Use on 16-1/2" x 7" P brakes. Contains 1244-D-1694 spacers.
A1-3236-Q-2123	18-1/8"	10-1/8"	1-1/2"	21/32"	6	7/16"	Use on 16-1/2" x 7" P and Q brakes. Replaces 331487, 331488
A-3264-S-227	18-1/8"	10-11/16"	1-1/4"	17/64"	6	7/16"	Use on 16-1/2" x 6" P brakes and 16-1/2" x 5" Q brakes.
A4-3264-T-228	18-1/8"	10-11/16"	1-1/4"	17/64"	6	7/16"	With spacers. Use on 16-1/2" x 6" P brakes.

# DUST SHIELDS

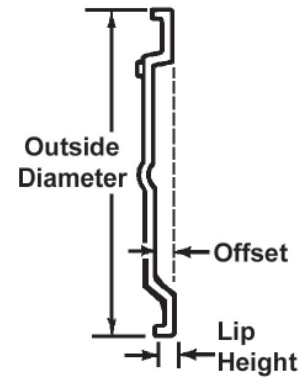

PART NUMBER	OUTER DIA.	INNER DIA.	OFFSET	LIP HEIGHT	NO. OF HOLES	SIZE OF HOLES	APPLICATION INFORMATION
<b>3264-D-160</b>	18-5/8"	11-11/16"	1-11/16"	2-1/32"	6	1/2"	Use on 16-1/2" x 5" P brakes.

**6**

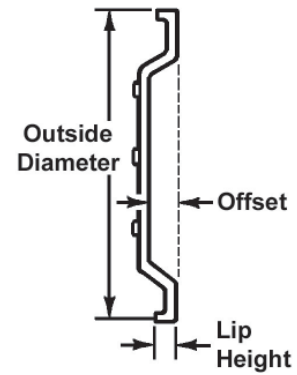
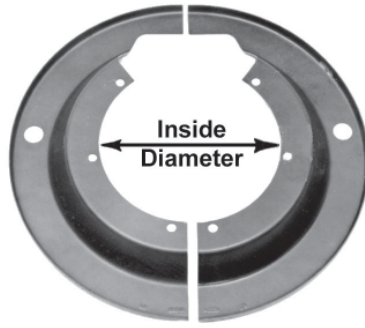

PART NUMBER	OUTER DIA.	INNER DIA.	OFFSET	LIP HEIGHT	NO. OF HOLES	SIZE OF HOLES	APPLICATION INFORMATION
<b>A-3236-Z-1274</b>	19-5/8"	9-5/8"	1-1/4"	2-1/32"	6	7/16"	P brakes.
<b>A1-3236-C-1823</b>	19-5/8"	10-1/8"	3/4"	2-1/32"	6	7/16"	Use on 18" P brakes.

# DUST SHIELD WASHERS



PART NUMBER	I.D.	O.D.	THICKNESS	REPLACES	APPLICATION INFORMATION
1229-R-512	1/4"	1/2"	1/32"		Use on 15" x 4" Q brakes.

## PLUGS

PART NUMBER	FLAP DIM.	PLUG DIM.	APPLICATION INFORMATION
-------------	-----------	-----------	-------------------------

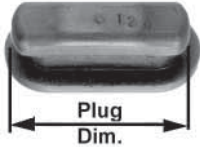

**R40H1456** 1-1/16" Eaton 15" x 4" front brakes Rubber



**1250-R-1214** 1-3/64" 1-11/32" Dust shield plug

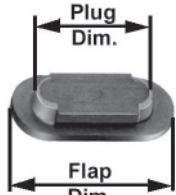

**1707-B-2** 1-1/2" 1-1/8" For 15" rear dust shields. Use on 16-1/2" P and Q brakes. Replaces L1785

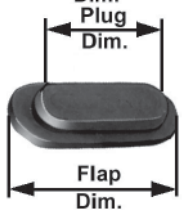

**1707-C-3** 1-13/16" 1-7/16" Use on 15" rear brake dust shields.

# DUST SHIELD KITS

## KIT 8070

16-1/2" x 7"

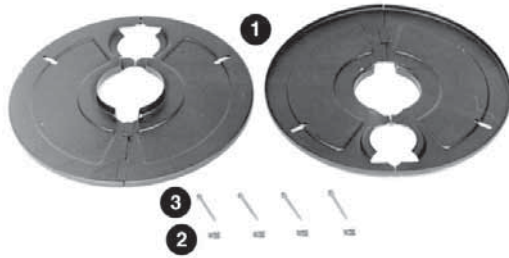

ITEM	QTY	PART NUMBER	DESCRIPTION
1	2	3264-L-1234	Dust Shield
2	4	1227-R-1422	Speed Nut
3	4	10-X-1525	Capscrew

### APPLICATION INFORMATION

Trailer axle dust shield for 16-1/2" x 7" cam brakes with spring suspensions (axle tube mounted). Services two brakes. All other applications should continue to use kit R009095.

## R009095

16-1/2" x 7"

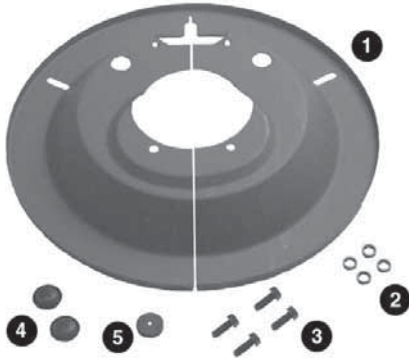

ITEM	QTY	PART NUMBER	DESCRIPTION
1	1	R600R0X	Dust Shield
2	4	1244-G-2217	Spacer
3	4	10-X-1423	Tapping Screw
4	2	1250-R-1214	Plug
5	1	3280-C-9155	Grommet

### APPLICATION INFORMATION

For trailer axles with fabricated spider. Services one brake. Replaces: E9095, E9095A, L3160